









# Installation Instructions Supertop<sup>®</sup> with Tinted Side and Rear Windows

## Vehicle Application

- Jeep Wrangler (JK)  
2007 – Current  
Part Number: 54716

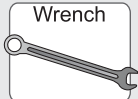
[www.Bestop.com](http://www.Bestop.com) - We're here to help! Visit our web site and click on ["Ask a Question"](#). Click here for more [Jeep Accessories by Bestop](#).

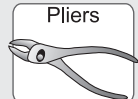
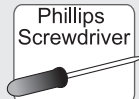
<b>INSTALLATION TIME</b>	<b>SKILL LEVEL</b>
 <b>3 Hours</b>	 <b>3 - Moderately Hard</b>

TOOLS			
 Phillips Screwdriver #2	 Wrench 10mm and 3/8"	 Power Drill #2 Phillips and 3/16" Bit	 Pliers
 Phillips Screwdriver #1	 Masking Tape	 Safety Glasses	



	<b>CAUTION</b>	Safety glasses should be worn at all times while installing this product.
---	----------------	---

<p><b>Installation Tips</b></p> <p>Before you begin installing this assembly, read all instructions thoroughly.</p> <p><b>For a smooth fit:</b></p> <p>For ease in installation, the product should be installed at temperatures above 72° F. Below this temperature, the fabric may contract an inch or more, making it difficult to fit to the vehicle. It is normal for fabric to contract and wrinkle when stored in the shipping carton. Within a few days after the installation, the fabric will relax and the wrinkles will disappear.</p>
--

<p><b>! WARNING</b> This product is designed primarily to enhance the appearance of the vehicle and to shield the occupants from ordinary weather conditions. Do not rely in any way on the components of this product to contain occupants within the vehicle, or to protect against injury or death in the event of an accident. This product will not protect the occupants from falling objects. Never operate the vehicle in excess of manufacturer's specifications.</p> <p><b>WEAR SEAT BELTS AT ALL TIMES</b></p> <p>Read and follow, precisely, all installation instructions provided when installing product. Failure to do so may result in a poor fit and could place occupants of the vehicle in a potentially dangerous situation.</p>
---

# Supertop® with Tinted Windows – Installation Instructions

Top Fabric	Qty - 1
Quarter Window, Right	Qty - 1
Quarter Window, Left	Qty - 1
Rear Window	Qty - 1
#2 Bow Hook and Loop Strip	Qty - 1
Soft Header Trim	Qty - 1
Hard Pillar Trim	Qty - 1

## Parts List and Hardware Identification

Header, Qty - 1, Part Number 440.72

B-Pillar Rail - Rt., Qty - 1, Part Number 440.76

B-Pillar Rail - Lt., Qty - 1, Part Number 440.77

Header Retainer, Qty - 1, Part Number 440.73

Upper Door Rail - Lt., Qty - 1, Part Number 440.75

Upper Door Rail - Rt., Qty - 1, Part Number 440.74

Side Bow - Lt., Qty - 1, Part Number 436.93

Side Bow - Rt., Qty - 1, Part Number 436.92

Long Rail Bracket, Qty - 2, Part Number 471.38

Short Rail Bracket, Qty - 2, Part Number 471.36

Knob, Qty - 2, Part Number 316.85

Bow Mount Bracket - Lt., Qty - 1, Part Number 433.83

Bow Mount Bracket - Rt., Qty - 1, Part Number 433.82

Backing Plate, Qty - 2, Part Number 442.68

Tailgate Retainer, Qty - 1, Part Number 440.94

Knob Bracket Assembly, Qty - 2, Part Number 471.13

#2 Bow, Qty - 1, Part Number 436.24

#3 Bow Extension, Qty - 2, Part Number 436.28

Side Bow Bracket - Lt., Qty - 1, Part Number 433.77

Side Bow Bracket - Rt., Qty - 1, Part Number 433.76

#3 Bow, Qty - 1, Part Number 436.25

Bow Pivot Bracket, Qty - 2, Part Number 411.80

Header Knob Plate, Part Number 445.10, Qty - 2

# Supertop® with Tinted Windows – Installation Instructions

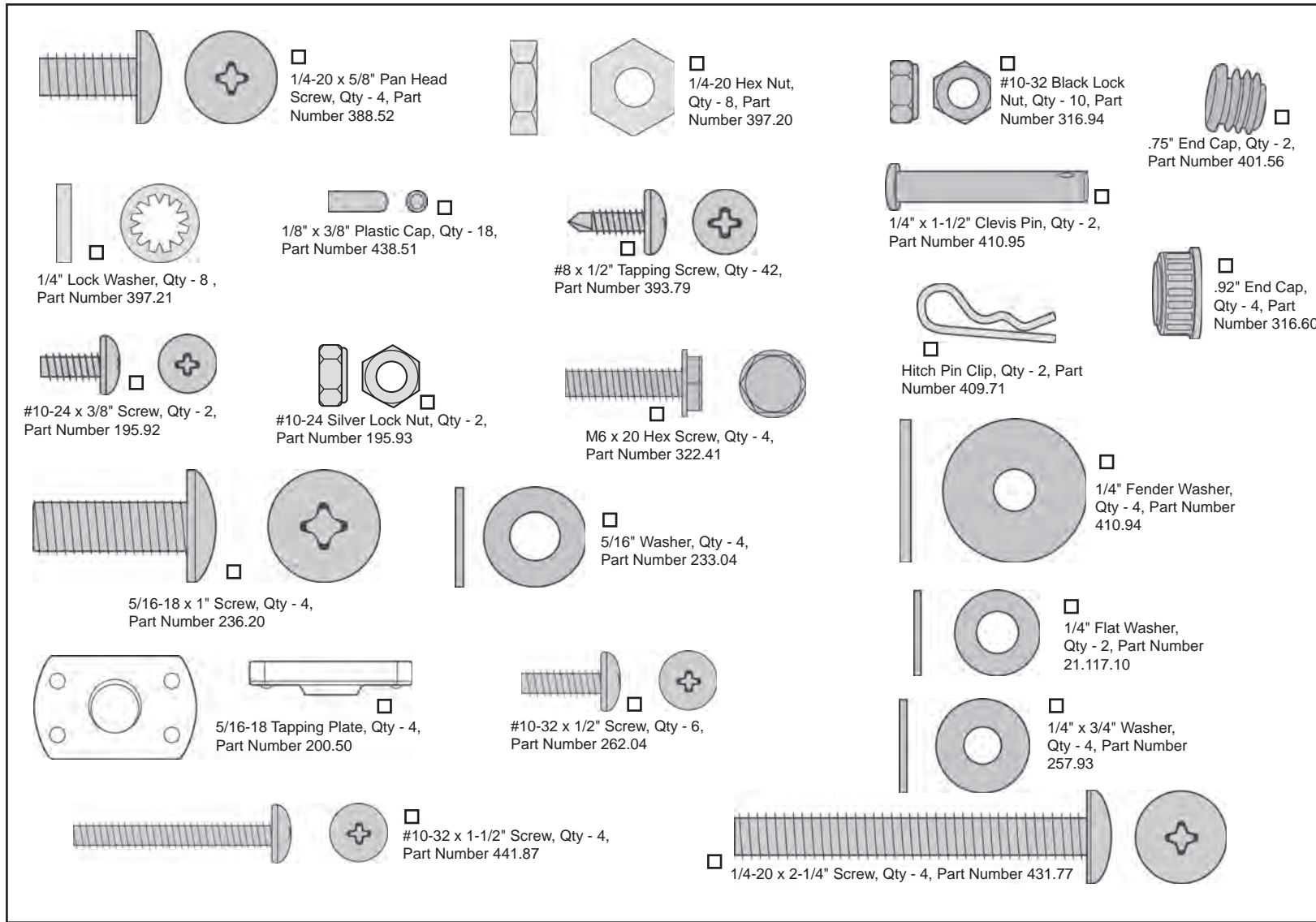

# Supertop® with Tinted Windows – Installation Instructions

## 1 Remove Quarter Windows and Rear Window

Refer to your owner's manual for instructions to remove any old hard or soft top components.

## 2 Install Side Bow Brackets

Unzip the sport bar pad and locate the tapped holes in the front sport bar hoop. Attach the right and left Side Bow Brackets to the sport bar with the M6 Hex Screws. Reinstall the sport bar pad.

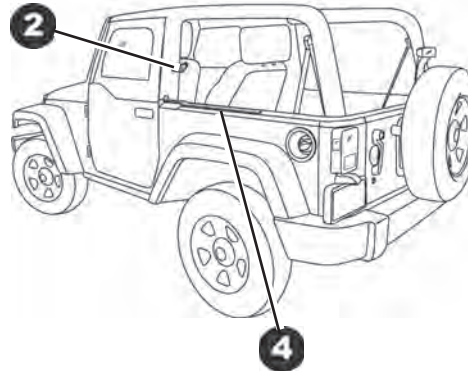
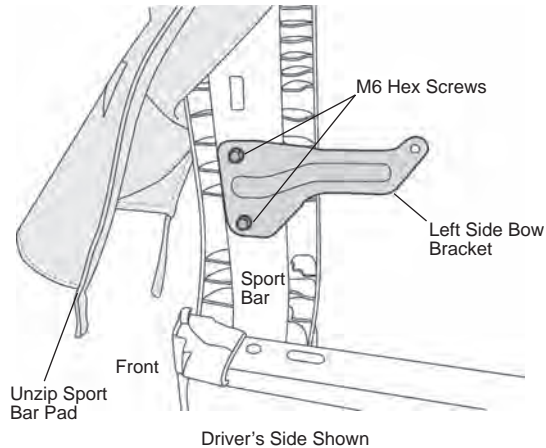

## 4 Install Bow Mount Brackets

Position the Bow Mount Brackets over the slots in the belt rail. Loosely attach the brackets with 5/16-18 x 1" Screws, 5/16-18 Tapping Plates and 5/16 Washers. Install the front screw first and the rear screw last.

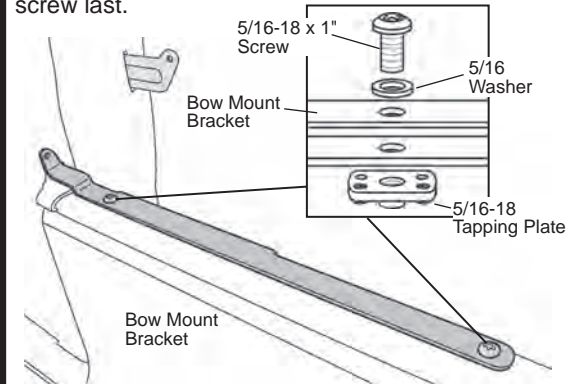

## 3 Install Fender Washer on Bow Mount Bracket

Slide a 1/4" Fender Washer over a 1/4" x 1-1/2" Clevis Pin and insert the pin through the slot of each Bow Mount Bracket from the outside. Slide on another Fender washer and secure each assembly with a Hitch Pin Clip.

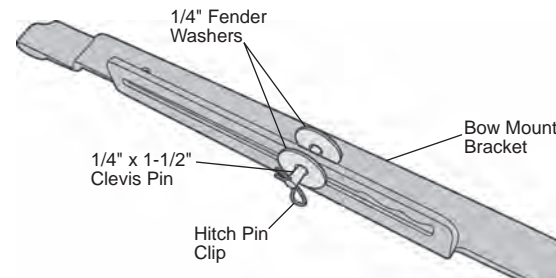

## 5 Install Rail Brackets on Upper Door Rails

Install a Short Rail Bracket over the front inboard holes of each Upper Door Rail with two (2) #8 x 1/2" Tapping Screws. Attach a Long Rail Bracket to the rear inboard holes of each Upper Door Rail with #8 x 1/2" Tapping Screws. Leave the screws loose for later adjustment.

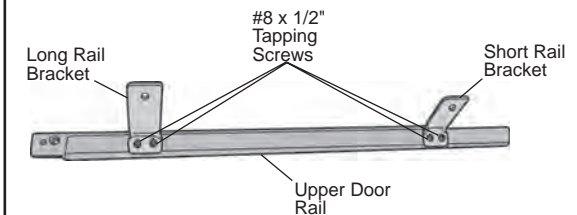

# Supertop® with Tinted Windows – Installation Instructions

## 6 Assemble Upper Door Rail to B-Pillar Rail

Attach the Left Upper Door Rail to the Left B-Pillar Rail with two (2) #10-32 x 1/2" Screws and two (2) #10-32 Black Lock Nuts with the screw head to the inside of the pillar. If necessary, squeeze the B-Pillar Rail together with pliers until the nut is started. Leave fasteners loose for later adjustment. Repeat on the other side.

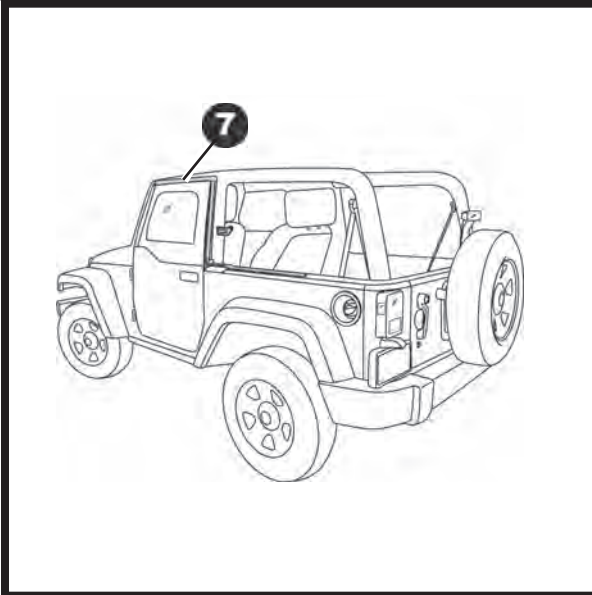
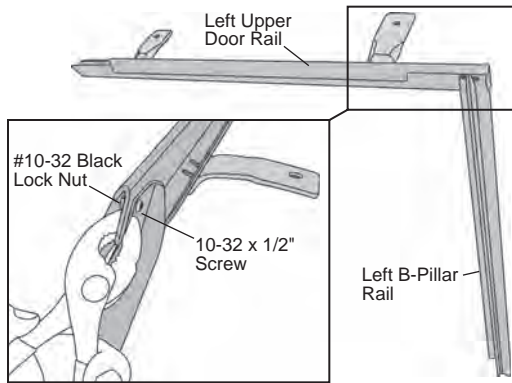

## 7 Install Door Rail Assemblies

Orient the Door Rail Assemblies on the vehicle with the Rail Brackets on top of the side sport bar and the B-Pillar Rails in front of the Bow Mount Brackets. Insert a 1/4-20 x 2-1/4" Screw with 1/4" x 3/4" Washer into the bottom hole and up through the top hole of the side sport bar. Use 1/4-20 Hex Nuts and 1/4" Lock Washers to secure the Rail Brackets. Attach each B-Pillar Rail to the Bow Mount Brackets with #10-32 x 1/2" Screws and #10-32 Black Lock Nuts. Shut the door and adjust the rail position for the best fit and seal. Tighten all Rail and Bow Mount Bracket fasteners. Push the Hard Pillar Trim groove over the inboard edge of the B-Pillar Rail. Trim excess and repeat on the other side.

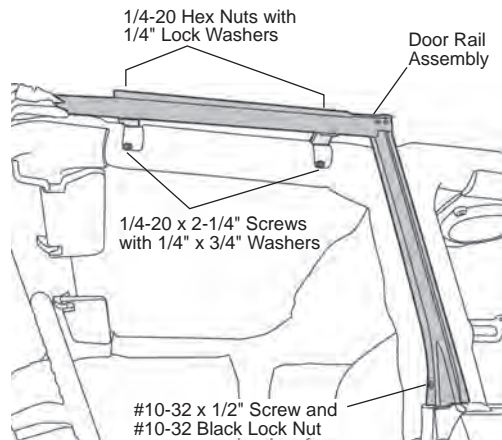

## 8 Assemble Bows

Insert the necked down end of a #3 Bow Extension into each end of the #3 Bow and align the holes. It may be necessary to drill out the holes with a 3/6" bit to allow the #10-32 x 1-1/2" Screws to go all the way through the joint.

Lay the bow down so the four (4) holes on the top of the bow point up. Position a Bow Pivot Bracket around the extension joint and align the holes. Connect each bracket to the bow with a #10-32 x 1-1/2" Screw and a #10-32 Black Lock Nut.

Lay the #2 Bow on top of the #3 Bow Assembly. Line up the holes on the end of the #2 Bow with the holes in the Bow Pivot Bracket. Attach the bow to the brackets with a #10-32 x 1-1/2" Screw and a #10-32 Black Lock Nut on each side.

Push a .922" End Cap into the end of each bow.

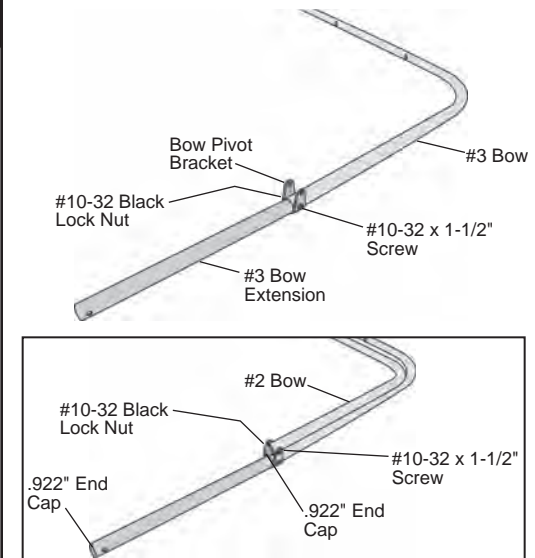

# Supertop® with Tinted Windows – Installation Instructions

## 9 Install Bows

Lay the Bow Assembly in the body tub with the #2 Bow facing up and the top of the #3 Bow on top of the tailgate. Disconnect the Hitch Pin Clip on one of the Bow Mount Brackets and slip the hole in the end of the #3 Bow over the Clevis Pin. Apply upward pressure on the inboard fender washer to bind the pin and hold it in place while installing the bow. Put a 1/4" Flat Washer on the Clevis Pin and reinstall the Hitch Pin Clip. Repeat on the other side.

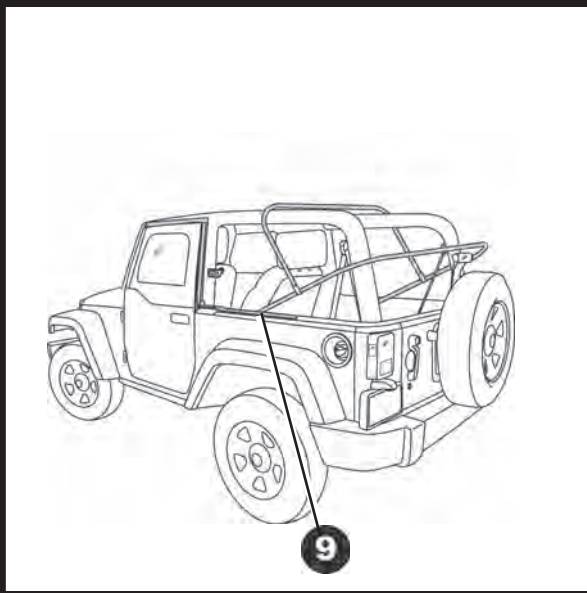
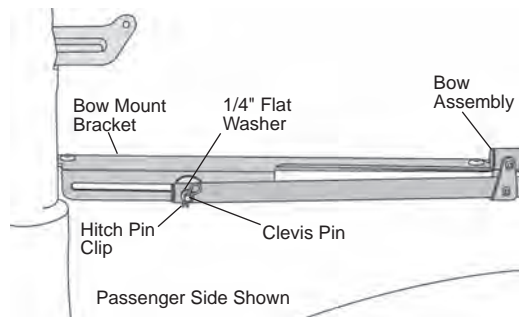

## 11 Install Side Bows on Header

Push a .75" End Cap into the front end of each Side Bow. Set the Side Bows on a table so the leg of the bow with the two holes points forward and the leg with the knuckle hangs down off the table. Set the right bow to your right and the left bow to your left. The pull knobs on the knuckles should face away from each other. Set the bottom of the Header on top of the bows and position the bows so the two holes in the bow line up with the two outboard holes in the Header. Attach the header to the bows with #8 x 1/2" Tapping Screws.

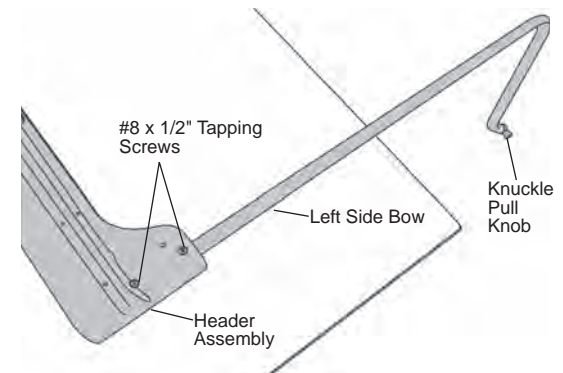

## 10 Install Knob Bracket Assembly on Header

Orient a Knob Bracket Assembly with the threaded insert toward the front. Place it over a set of 1/4" holes on the rear flange of the Header. Mount it to the Header with two (2) 1/4-20 x 5/8" Pan Head Screws, a Backing Plate, a 1/4" Lock Washer, and 1/4-20 Hex Nut. Repeat with the other Knob Bracket Assembly.

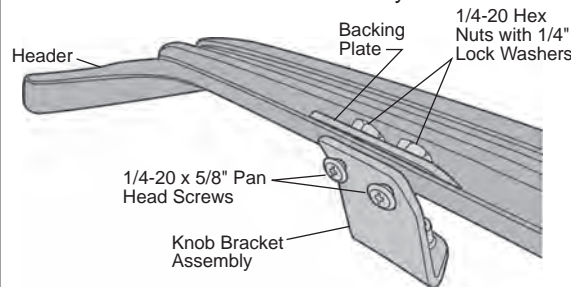

# Supertop® with Tinted Windows – Installation Instructions

## 12 Install 2 Bow Hook and Loop Strip

Unfold the Top Fabric and locate the hook and loop flap on the underside of the top. Attach the hook side of the #2 Bow Hook and Loop Strip to the loop side of the flap.

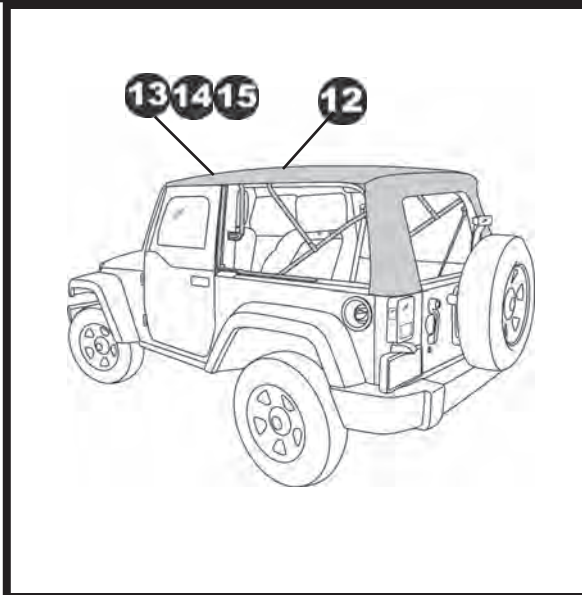
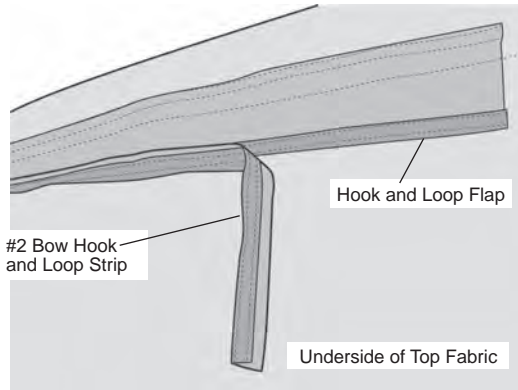

## 14 Secure Header Retainer

Flip the fabric over to access the Header. Secure the right and left rear corners of the retainer to the Header with two (2) #10-24 x 3/8" Screws and #10-24 Silver Hex Nuts. Push a 1/8" x 3/8" Plastic Cap onto the points of each of the tapping screws.

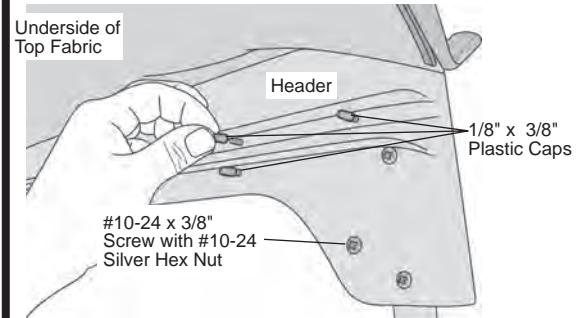

## 13 Secure Top Fabric to Header and Header Retainer

Orient the Header Assembly with the side bows pointing up. Push the Soft Header Trim groove over the leading edge of the Header. Put the front edge of the Header into the pocket along the front of the Top Fabric. Position the Top Fabric on the header so the welt on the fabric edge is against the step in the Header. Center the fabric on the Header and hold it in place with masking tape. Lay the Header Retainer on the Header and position it so the fabric welt is captured between the Header and the Retainer. Line up the holes and secure the Retainer to the Header with eighteen (18) #8 x 1/2" Tapping Screws. Attach the Retainer to each Side bow with four (4) #8 x 1/2" Tapping Screws.

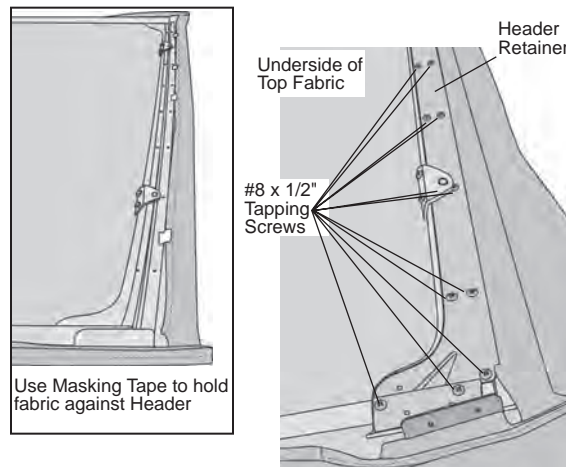

## 15 Secure Top Fabric Retainer to Header Retainer

Fold the front corner of the fabric around the header. Insert a #1 Phillips Screwdriver into the rear hole in the deck retainer and into the header retainer. Use the Screwdriver as a pry bar to stretch the deck rearward until the front retainer holes line up. Attach each deck retainer to the header retainer with two (2) #8 x 1/2" Tapping Screws.

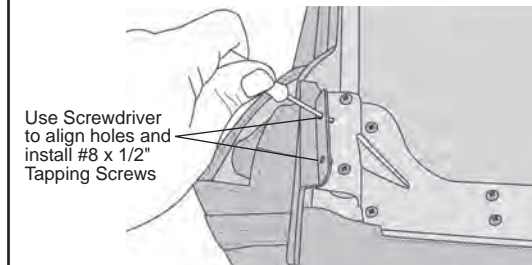

# Supertop® with Tinted Windows – Installation Instructions

## 16 Secure Side Bows to Side Bow Bracket

Lay the header/deck assembly in the body tub with the knuckle end of the Side Bows pointing up. Attach each Side Bow to a Side Bow Bracket by pulling out on the knuckle knob and sliding the knuckle over the Side Bow Bracket. Release the knob and make sure the knuckle pin goes into the hole in the bracket.

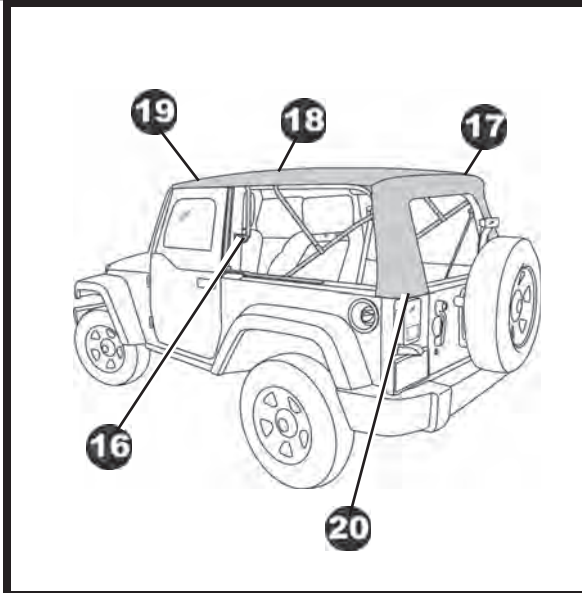
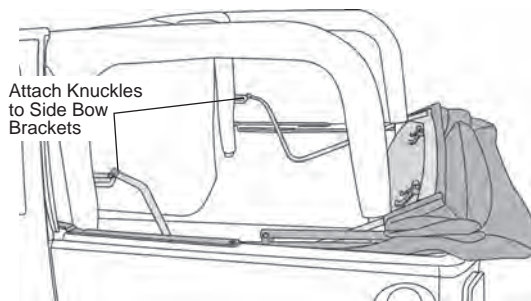

## 19 Secure Header to Windshield

Lift the Header in the center and rotate it to the windshield. Insert a Knob through a Header Knob Plate so the cup in the plate faces up. Guide the Knob between the windshield and the footman loop and thread it into the insert of the Knob Bracket Assembly. Repeat on the other side. Alternate tightening the Knobs while keeping the Header centered until the Knobs are tight.

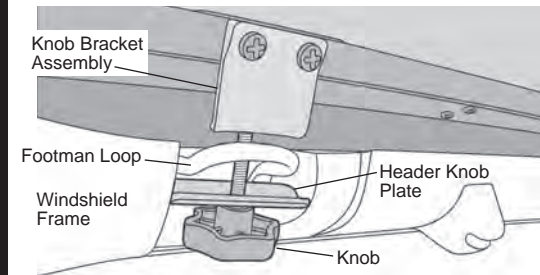

## 17 Attach Top to Rear Bow

Raise the header and bow slightly to allow you to attach the rear bow flaps, that are inside the top above the rear window opening, to the rear bow. Use four (4) #8 x 1/2" Tapping Screws to secure the flaps to the bow.

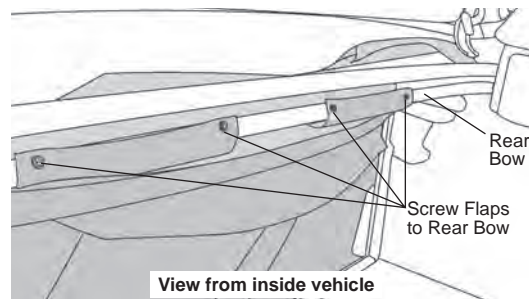

## 18 Secure Center Bows

Wrap the hook and loop flaps around the #2 Bow in the center of the top.

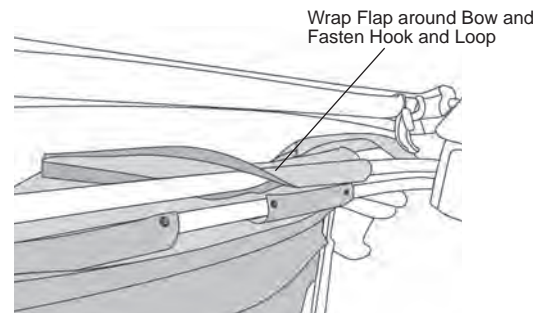

## 20 Secure Rear Corners

Make sure the #3 bow is at the forward end of the Bow Mount slot. Insert the plastic strip in the rear corner of the top into the channel in the body.

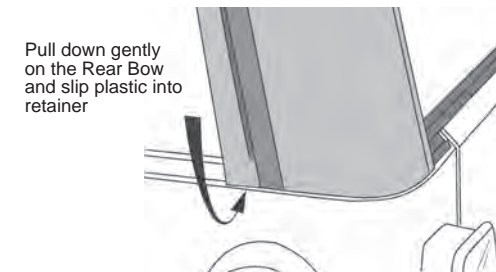



# Supertop® with Tinted Windows – Installation Instructions

## 21 Adjust Tension on Top

Pull the legs of the #3 Bow toward the rear until they engage in the front notch in the Bow Mount Brackets. Over time as the top gets looser you can slide the bow further back to tighten the top.

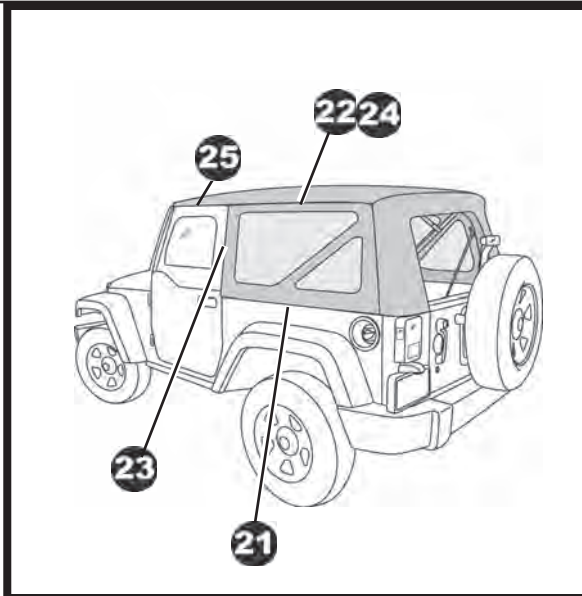
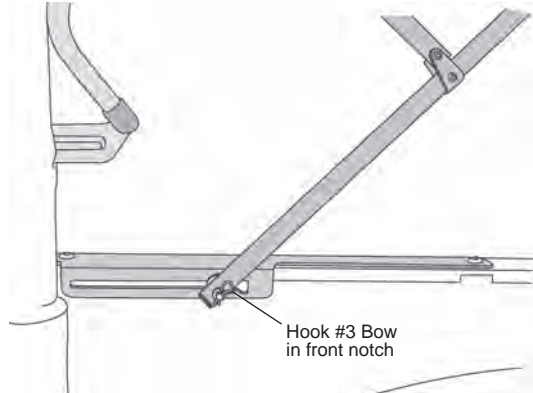

## 24 Secure Quarter Window

Close the zipper and slip the plastic along the bottom of the Side Window into the channel on the vehicle. Fasten the hook and loop strip above the window to the top.

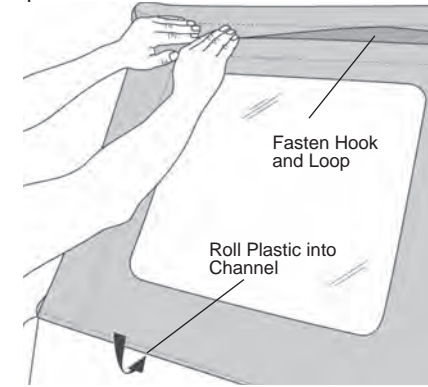

## 22 Attach Quarter Window Zippers

Start the zipper on the Quarter Window and close it 1-2 inches.

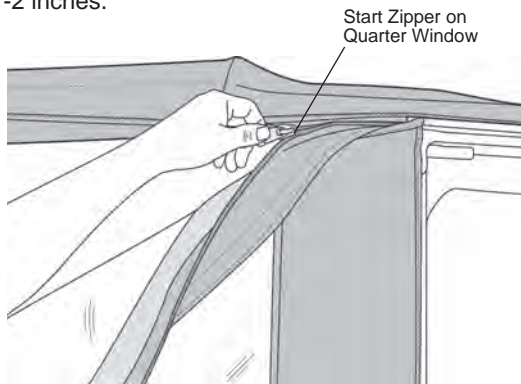

## 23 Secure Front of Quarter Window

Roll the plastic strip along the front of the Quarter Window into the channel in the Door Surround.



## 25 Secure Top above Door Openings

Slip the plastic strips above the doors into the channel on the vehicle.

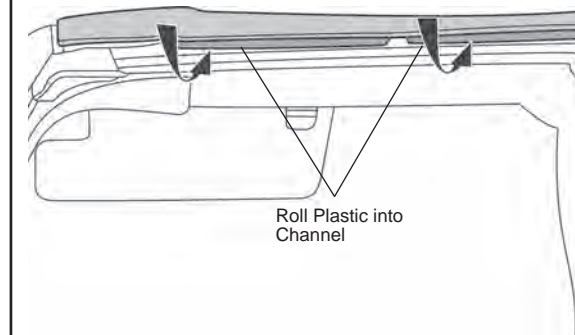

## Supertop® with Tinted Windows – Installation Instructions

### 26 Install Tailgate Retainer on Rear Window

Remove the Rear Window from the box and lay it flat with the backing side up. Locate the Tailgate Retainer. The bar has a “C” shaped channel, when viewed from the end. Orient the retainer with the round seal down and slide the “C” channel on the retainer onto the tubed strip sewn to the backing side of the Rear Window.

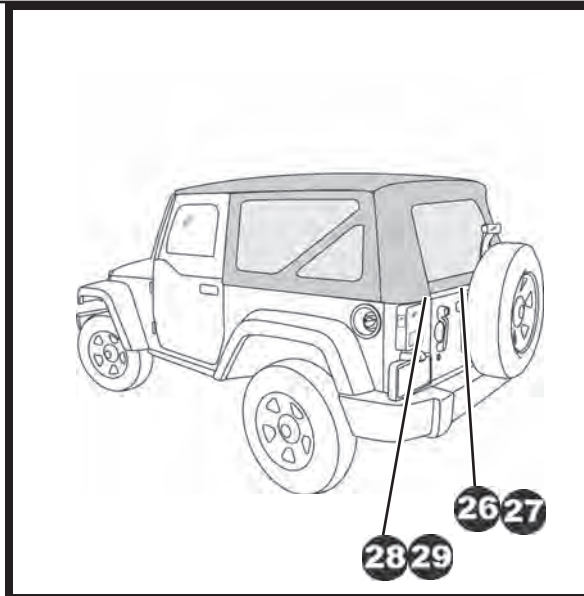
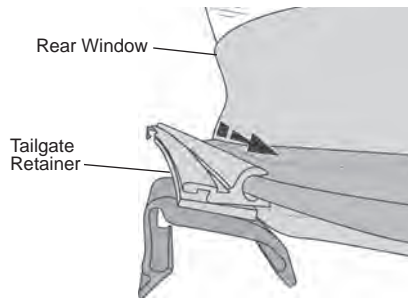

### WARNING

When operating the vehicle without the Quarter Windows, remove the Rear Window for proper ventilation.

### 29 To Fold the Top Down Remove Quarter Windows and Rear Window

Remove the Quarter Panels and the Rear Window. Release the plastic strip from the retainer along the bottom and front of the panel

To roll up the Rear Window, remove the Tailgate Bar and open the zippers on each side of the window to the top. Start at the bottom and roll the window to the inside. Avoid wrinkles in the fabric and window. Secure it in place with the elastic garters inside of the top.

### 27 Install Tailgate Retainer on Vehicle

Hook the bottom of each clip on the bottom of the Tailgate Retainer under the front edge of the belt rail. Roll the retainer toward the rear of the vehicle until it clips into place.

To remove the retainer, lift up on the flange that is located on the front of the clip.

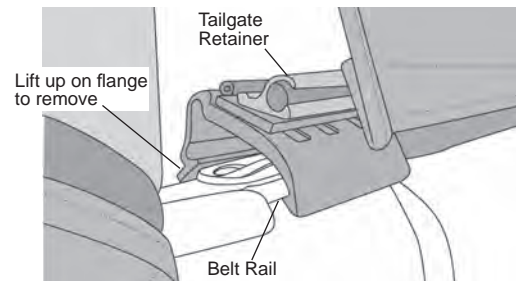

### 28 Secure Rear Window Zippers

To start the zipper, pull the two sliders as far down as possible on the driver's side of the window in order to catch the sliders to the pin.

Once the zipper is caught, start the top slider 1/2". Then hold up the top of the window with one hand and close the zipper with the other. The zipper is sandwiched between layers of fabric in the corners so be careful not to catch extra fabric in the zipper. Close the zipper.

Make sure that the Tailgate Bar is centered and is securely in the mounts. Then tuck the flaps on the Rear Window under the top fabric.

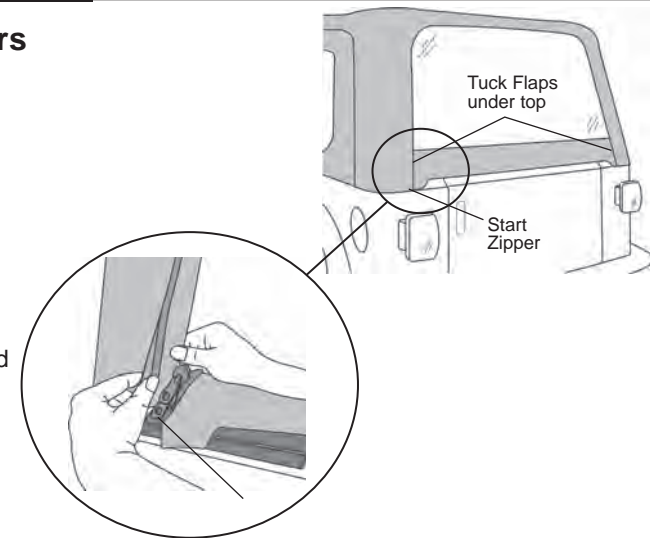

## Supertop® with Tinted Windows – Installation Instructions

---

### 30 To Fold the Top Down Collapse Top

Release the front of the top from the windshield. Raise the front of the deck and collapse the rear bows, tucking the two plastic strips above the door openings inside of the bows. Wrap the fabric around the bows, then tuck the rear legs of the top under the bows.

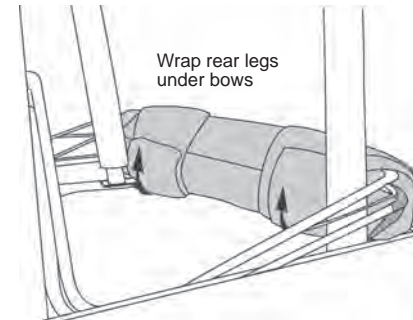
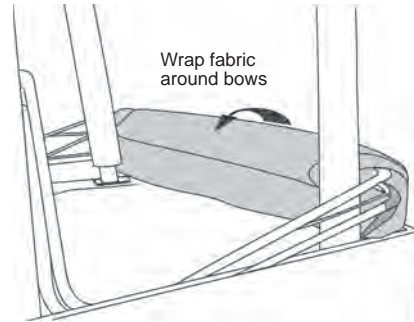
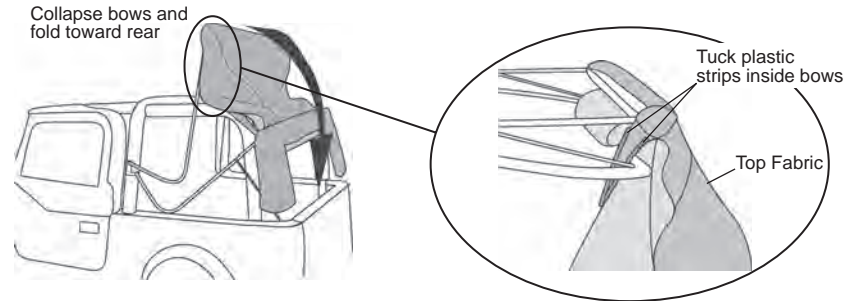

# Supertop® with Tinted Windows – Installation Instructions

## Care and Maintenance of your Bestop Product

Your Bestop product is made of the finest materials available. To keep it looking new and for the maximum possible wear, it will need periodic cleaning and maintenance.

**Washing:** The fabric should be washed often using soap, warm water and a soft bristle brush. Rinse with clear water to remove all traces of soap or use Bestop-recommended Bestop Cleaner and Bestop Protectant. Bestop Cleaner and Bestop Protectant are specially formulated to provide a total cleaning and protection system. Bestop Cleaner will not harm vehicle finish, is biodegradable and environmentally friendly. Bestop Protectant protects against UV-fading, cracking and hardening.

**Windows:** Keep windows clean to avoid scratching. DO NOT use a brush on the windows! Wash with a water-soaked cloth or sponge and a mild dishwashing detergent or use Bestop-recommended Bestop Vinyl Window Cleaner, which safely cleans and protects vinyl windows while helping prevent UV damage. NEVER WIPE THE WINDOWS WHEN THEY ARE DRY. Be careful when cleaning snow or frost from the vinyl windows since they are easily scratched and may crack at low temperatures. DO NOT roll the sides or rear window in cold weather. The windows become stiff and will crack.

**Zippers:** Keeping the zipper cleaned and lubricated with a silicone lubricant will help prevent damage and keep the zippers in a smooth working condition. If a zipper opens behind the slider, the slider may have been spread apart. This problem can usually be repaired by using an ordinary pair of pliers to bring the sides back into parallel. Return slider to the end of the zipper in the normal Open position. Squeeze lightly at first and test the zipper. If the zipper continues to remain open squeeze more firmly with the pliers and try the zipper again. Repeat this procedure until the zipper operates correctly.

**Water:** Seeping through at the seams may be stopped by applying 3-M Scotchgard® on the inside of the seams. Rips in the fabric may be repaired with Bondex® iron on patches. Iron the patches to the Inside of the top, carefully following the Bondex® instructions.

**Snaps:** Keep snaps cleaned and lubricated with silicone to help prevent snaps from sticking to the studs. If a snap does become stuck to a stud, use a screwdriver and GENTLY pry apart to prevent permanent damage to the snap or the top fabric.

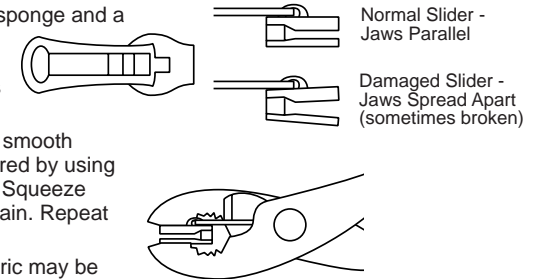

## LIMITED WARRANTY

We warrant our product to be free from defects in material and workmanship, for the terms specified below, provided there has been normal use and proper maintenance. This warranty applies to the original purchaser only. All remedies under this warranty are limited to the repair or replacement of any item or items found by the factory to be defective within the time period specified. If you have a warranty claim, first you must call our factory at the number below for instructions. You must retain proof of purchase and submit a copy with any items returned for warranty work. Upon completion of warranty work, if any, we will return the repaired or replaced item or items to you freight prepaid. Damage to our products caused by accidents, fire, vandalism, negligence, misinstallation, misuse, Acts of God, or by defective parts not manufactured by us, is not covered under this warranty.

THE WARRANTY TIME PERIOD IS AS FOLLOWS FOR REPLACE-A-TOP™, SAILCLOTH REPLACE-A-TOP™, SUPERTOP®, SUPERTOP® REPLACEMENT SKINS, SUNRIDER®, AND TIGERTOP®: TWO YEARS FROM DATE OF PURCHASE.

THE WARRANTY TIME PERIOD IS AS FOLLOWS FOR ALL OTHER "SOFT GOODS" MANUFACTURED BY OUR COMPANY (USING PRIMARILY VINYL, PLASTICS, AND/OR FOAM): ONE YEAR FROM DATE OF PURCHASE.

THE WARRANTY TIME PERIOD IS AS FOLLOWS FOR ALL OTHER "HARD GOODS" MANUFACTURED BY OUR COMPANY (USING PRIMARILY METALS, PLASTICS, AND/OR FIBERGLASS): ONE YEAR FROM DATE OF PURCHASE.

ANY IMPLIED WARRANTIES OF MERCHANTABILITY AND/OR FITNESS FOR A PARTICULAR PURPOSE CREATED HEREBY ARE LIMITED IN DURATION TO THE SAME DURATION AND SCOPE AS THE EXPRESS WRITTEN WARRANTY. OUR COMPANY SHALL NOT BE LIABLE FOR ANY INCIDENTAL OR CONSEQUENTIAL DAMAGE.

Some states do not allow limitations on how long an implied warranty lasts, or the exclusion or limitation of incidental or consequential damages, so the above limitations or exclusions may not apply to you. This warranty gives you specific legal rights, and you may also have other rights which vary from state to state.

For further information or request for warranty work, please contact:

Bestop Inc., Customer Service  
Toll-Free: (800)845-3567  
Main: (303)465-1755  
E-mail: [csbestop@Bestop.com](mailto:csbestop@Bestop.com)  
Website: [www.Bestop.com](http://www.Bestop.com)

